

# Mini cylinder, Series CSL-RD

- Version: ISO model
- Ø 16 mm
- Ports M5
- double-acting
- with magnetic piston
- Cushioning Pneumatically adjustable
- with integrated rear eye
- Piston rod External thread
- ATEX optional
- suitable for use in food processing



Standards	ISO 6432
Certificates	ATEX optional
Compressed air connection	Internal thread
Working pressure min./max.	1 ... 10 bar
Ambient temperature min./max.	-20 ... 80 °C
Medium temperature min./max.	-20 ... 80 °C
Medium	Compressed air
Max. particle size	50 µm
Oil content of compressed air	0 ... 5 mg/m <sup>3</sup>
Pressure for determining piston forces	6.3 bar

## Technical data

	16 mm	20 mm	25 mm
Piston Ø	16 mm	20 mm	25 mm
Piston rod thread	M6	M8	M10x1,25
Ports	M5	G 1/8	G 1/8
Piston rod Ø	6 mm	8 mm	10 mm
Stroke 25	R412020409	R412020453	R412020497
50	R412020410	R412020454	R412020498
80	R412020411	R412020455	R412020499
100	R412020412	R412020456	R412020500
125	R412020413	R412020457	R412020501
160	R412020414	R412020458	R412020502
200	R412020415	R412020459	R412020503
250	R412020416	R412020460	R412020504
320	R412020417	R412020461	R412020505
400	R412020418	R412020462	R412020506
500	R412020419	R412020463	R412020507

## Technical information

Piston Ø	16 mm	20 mm	25 mm
Retracting piston force	109 N	166 N	260 N
Extracting piston force	127 N	198 N	309 N

The pressure dew point must be at least 15 °C under ambient and medium temperature and may not exceed 3 °C .

The oil content of compressed air must remain constant during the life cycle.

Use only the approved oils from AVENTICS. Further information can be found in the "Technical information" document (available in the MediaCentre).

Clamping piece for magnetic field sensor necessary

ATEX-certified cylinders with identification II 2G c IIB T4 / II 2D c IP65 T135°C X can be generated in the Internet configurator.

The operating temperature range for ATEX-certified cylinders is - 20 °C ... 50 °C .

## Technical information

Material	
Cylinder tube	Stainless steel
Piston rod	Stainless steel
Piston	Aluminum
Front cover	Stainless steel, Electropolished
End cover	Stainless steel, Electropolished
Seal	Nitrile butadiene rubber
Nut for cylinder mounting	Stainless steel
Nut for piston rod	Stainless steel
Scraper	Polyurethane
Guide bushing	Plastic

## Dimensions

### Dimensions

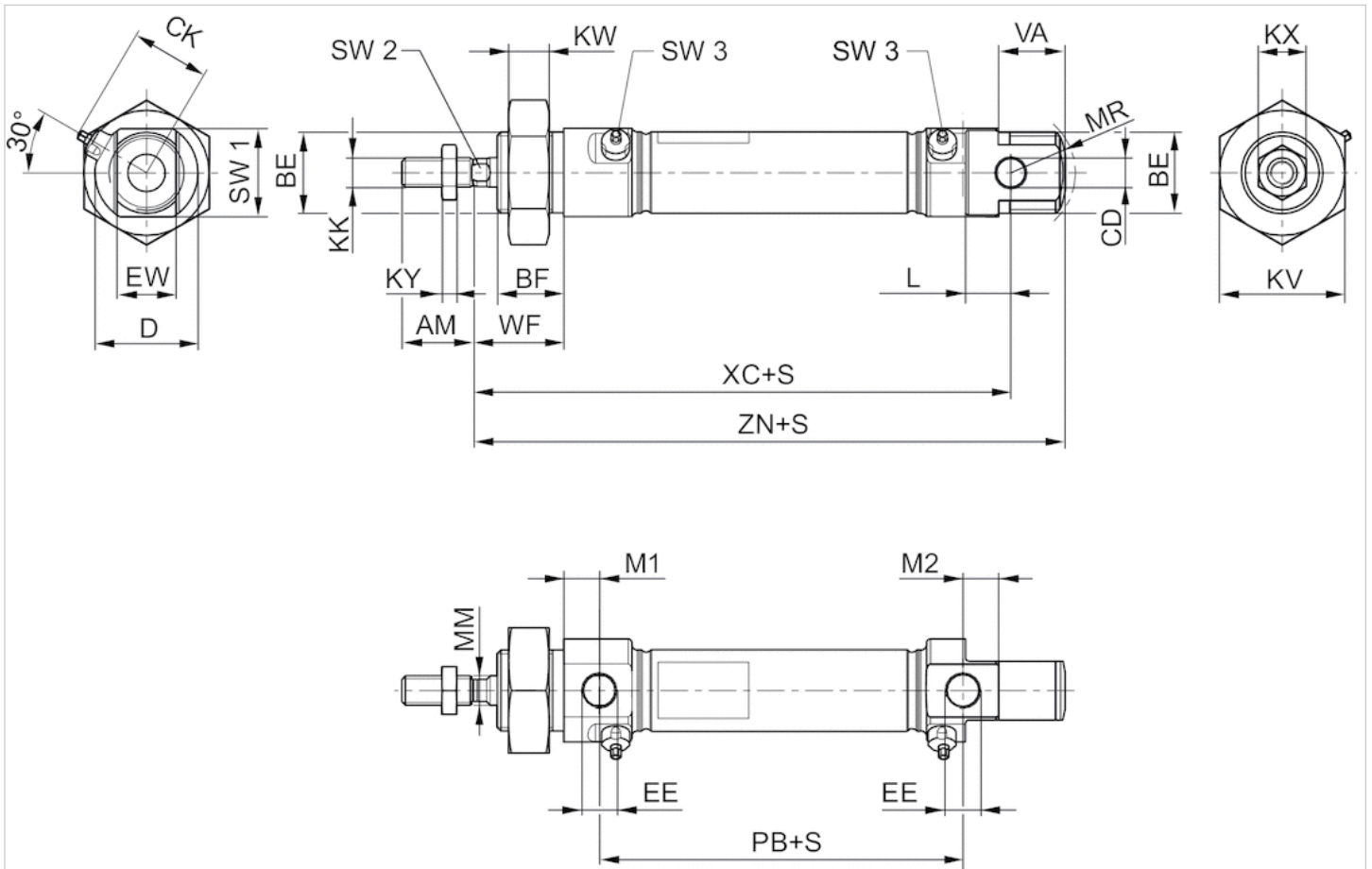

S = stroke

## Dimensions

Piston Ø	AM-2	BE	BF	CD H9	CK 1)	D	EE	EW d13	KK	KV	KW	KX	KY	L 2)
16 mm	16	M16x1,5	16	6	19.5	22	M5 t=5	12	M6	24	8	10	3.2	9
16 mm	16	M16x1,5	16	6	19.5	22	M5 t=5	12	M6	24	8	10	3.2	9
20 mm	20	M22x1,5	18	8	23	28	G 1/8 t=8	16	M8	34	11	13	4	12
25 mm	22	M22x1,5	20	8	25.5	33	G 1/8 t=8	16	M10x1,25	34	11	17	5	12

Piston Ø	M1/M2	MM f8	MR	PB ±1	VA	WF ±1,4	XC ±1	ZN ± 1	SW 1	SW 2 h13	SW 3
16 mm	6.7	6	16	43.6	16	22	82	94.7	20	5	2.5
16 mm	6.7	6	16	43.6	16	22	82	94.7	20	5	2.5
20 mm	9.7	8	18	48.6	18	24	95	109.7	24	6	2.5
25 mm	9.7	10	19	51.8	20	28	104	119.7	28	8	2.5

1) max.

2) Min.

# Diagrams

## Cushioning diagram

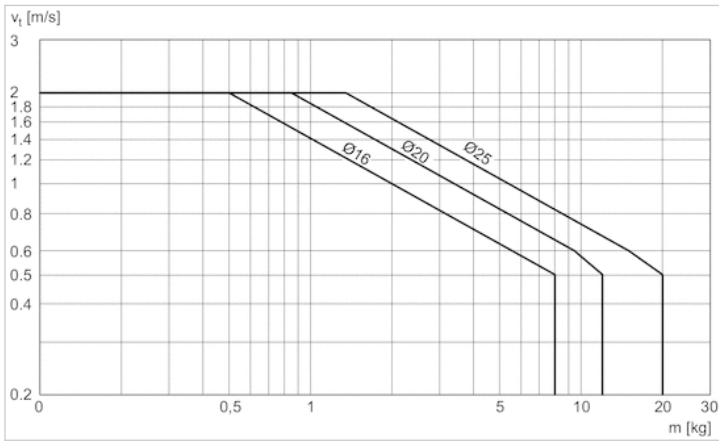

v = Piston velocity [m/s] m = Cushionable mass [kg]